

# BATTLETECH™

## BATTLEMECH RECORD SHEET

Armor Factor - 96

### ARMOR DIAGRAM

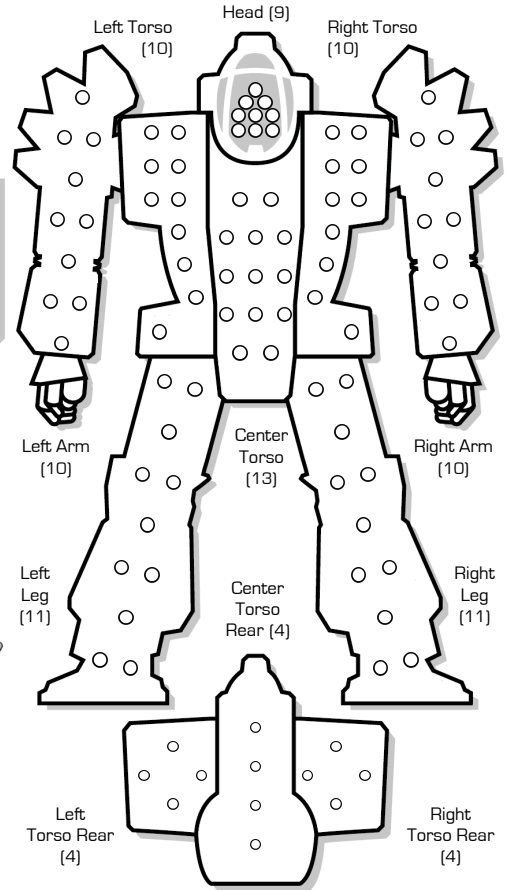

### 'MECH DATA

Type: Spider SDR-8Xr

Movement Points: **Tonnage:** 30  
 Walking: 8 **Tech Base:** Inner Sphere  
 Running: 12 **Rules Level:** Advanced  
 Jumping: 8 [10] **Role:** Scout

### WARRIOR DATA

Name: \_\_\_\_\_  
 Gunnery Skill: \_\_\_\_\_ Piloting Skill: \_\_\_\_\_  
 Hits Taken 

1	2	3	4	5	6
3	5	7	10	11	Dead

  
 Consciousness#

### Weapons & Equipment Inventory [hexes]

Qty	Type	Loc	Ht	Dmg	Min	Sht	Med	Lng
1	ER Small Laser	H	2	3	—	2	4	5
2	ER Small Laser	CT	2	3	—	2	4	5
1	ER Small Laser	RT	2	3	—	2	4	5
1	ER Small Laser	LT	2	3	—	2	4	5
1	Partial Wing	LT/RT	0	—	—	—	—	—
1	Sword	RA	0	4	—	1	—	—

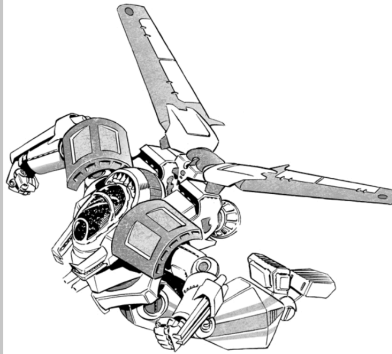

BV: 754



### CRITICAL HIT TABLE

Location	Hit 1	Hit 2	Hit 3	Hit 4	Hit 5	Hit 6
<b>Head</b>	1. Life Support	2. Sensors	3. Cockpit	4. ER Small Laser	5. Sensors	6. Life Support
<b>Left Arm</b>	1. Shoulder	2. Upper Arm Actuator	3. Lower Arm Actuator	4. Hand Actuator	5. Endo Steel	6. Endo Steel
<b>Right Arm</b>	1. Shoulder	2. Upper Arm Actuator	3. Lower Arm Actuator	4. Hand Actuator	5. Double Heat Sink	6. Double Heat Sink
<b>Center Torso</b>	1. Endo Steel	2. Endo Steel	3. Endo Steel	4. Endo Steel	5. Endo Steel	6. Endo Steel
<b>Left Torso</b>	1. XL Engine	2. XL Engine	3. XL Engine	4. Partial Wing	5. Partial Wing	6. Partial Wing
<b>Right Torso</b>	1. Double Heat Sink	2. Sword	3. Sword	4. Endo Steel	5. Endo Steel	6. Roll Again
<b>Left Leg</b>	1. Gyro	2. XL Engine	3. XL Engine	4. XL Engine	5. ER Small Laser	6. ER Small Laser
<b>Right Leg</b>	1. XL Engine	2. XL Engine	3. XL Engine	4. Partial Wing	5. Partial Wing	6. Partial Wing
<b>Left Torso Rear</b>	1. Partial Wing	2. Jump Jet	3. Jump Jet	4. Jump Jet	5. Jump Jet	6. ER Small Laser
<b>Right Torso Rear</b>	1. Partial Wing	2. Jump Jet	3. Jump Jet	4. Jump Jet	5. Jump Jet	6. ER Small Laser
<b>Left Arm (5)</b>	1. Partial Wing	2. Jump Jet	3. Jump Jet	4. Jump Jet	5. Jump Jet	6. ER Small Laser
<b>Right Arm (5)</b>	1. Partial Wing	2. Jump Jet	3. Jump Jet	4. Jump Jet	5. Jump Jet	6. ER Small Laser
<b>Left Leg (7)</b>	1. Hip	2. Upper Leg Actuator	3. Lower Leg Actuator	4. Foot Actuator	5. Endo Steel	6. Endo Steel
<b>Right Leg (7)</b>	1. Hip	2. Upper Leg Actuator	3. Lower Leg Actuator	4. Foot Actuator	5. Endo Steel	6. Endo Steel

Engine Hits ○○○○  
 Gyro Hits ○○  
 Sensor Hits ○○  
 Life Support ○

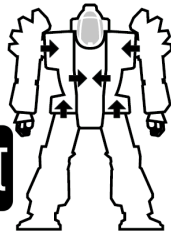

### INTERNAL STRUCTURE DIAGRAM

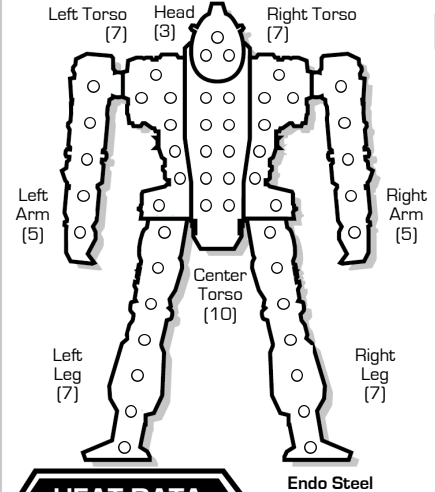

### HEAT DATA

Heat Level*	Effects	Heat Sinks: 10 [23]
30	Shutdown	○
28	Ammo Exp. avoid on 8+	○
26	Shutdown, avoid on 10+	○
25	-5 Movement Points	○
24	+4 Modifier to Fire	○
23	Ammo Exp. avoid on 6+	○
22	Shutdown, avoid on 8+	○
20	-4 Movement Points	○
19	Ammo Exp. avoid on 4+	○
18	Shutdown, avoid on 6+	○
17	+3 Modifier to Fire	○
15	-3 Movement Points	○
14	Shutdown, avoid on 4+	○
13	+2 Modifier to Fire	○
10	-2 Movement Points	○
8	+1 Modifier to Fire	○
5	-1 Movement Points	○

### Heat Scale

Heat Level	Overflow
30*	○
29	○
28*	○
27	○
26*	○
25*	○
24*	○
23*	○
22*	○
21	○
20*	○
19*	○
18*	○
17*	○
16	○
15*	○
14*	○
13*	○
12	○
11	○
10*	○
9	○
8*	○
7	○
5*	○
4	○
3	○
2	○
1	○
0	○